

United Air Specialists, Inc.

a CLARCOR company

C Series



CYCLONE DUST COLLECTORS

Clean air. It's what we do.®

C SERIES CYCLONE DUST COLLECTORS

The Most
Effective Way To
Remove
Large Size
Contaminants
from your factory.

HIGH-EFFICIENCY CYCLONE SEPARATOR

The C Series Cyclone is designed to effectively remove large to moderate-size particles (chips, metal grindings, sawdust) from the air stream. Used alone or in conjunction with another dust collector, the Cyclone separates coarse contaminants from fine, non-visible particles, and exhausts clean air.

UAS' Cyclone dust collector offers airflow capacities ranging from 800 to 13,000 CFM. Its high-efficiency performance is accomplished by means of the unit's long tapered cone, high-velocity inlet and welded helix. Dirty air enters the unit at a high speed and is then spun around in a spiral motion, throwing particles against its cone wall. Centrifugal force pushes the larger or heavy dust particles down through the narrow part of the cone and into a collection drum or hopper. Cleaned air runs back up through the center of the unit and is discharged back to the atmosphere or into a UAS after-filter for further processing.

APPLICATIONS

- Buffing
- Bulk Powder
- Conveying
- Fiberglass/Plastic
- Grinding
- Machining
- Polishing
- Sawing
- Woodworking



Clean air. It's what we do.®

OPTIONS AND ACCESSORIES

UAS provides a comprehensive selection of options and accessories to enhance the performance of your C Series Cyclone dust collector. Some of these include:

- **Explosion Relief Vent**—Minimizes damage and provides a degree of personal protection in the unlikely event of an explosion that may result when collecting explosive dusts.
- **Silencer Package**—Duct-type and acoustical foam-lined silencers reduce unit noise levels.
- **Fully Welded Construction**—Provides a complete, airtight seal to meet unique specifications.
- **After-Filter Magnehelic® Gage Kit**—Monitors pressure drop to indicate when filters need to be changed.
- Access doors
- Aluminum fan wheel
- Drum lid latch kit/slide gate
- Explosion-proof motor
- Explosion venting
- Increased hopper clearance
- Leg extensions
- Lined plenum
- 208/3/60 motor option
- Scroll outlet
- Sprinkler heads
- Stainless steel
- Starter panel with fused disconnect
- Throw out bin

C SERIES CYCLONE CONFIGURATIONS

Model	CFM	Motor (Hp)	Overall Height (inches)*					Weight (lbs)***	After-filter Options	
			Cyclone	1D (One Drum)	2D (Two Drums)	60H (60ft ³ Hopper)	110H (110ft ³ Hopper)		Interior	Exterior
C-190	800-1,200	–	49 1/8"	92 7/8"	114 3/4"	193 1/2"	209 1/2"	235	–	–
C-192	800-1,200	2	64 3/4"	108 1/4"	130 3/8"	209 1/8"	225 1/8"	320	AF192	–
C-200	1,250-2,250	–	62 3/16"	108 3/16"	121 3/16"	204 15/16"	220 15/16"	320	–	–
C-203	1,250-2,000	3	79 3/16"	125 3/16"	137 3/16"	222"	238 5/8"	430	AF4, C9-E	C9-W
C-205	1,500-2,250	5	80 9/16"	126 9/16"	138 9/16"	223 3/8"	240"	450		
C-240	2,000-3,500	–	73"	119 1/8"	131 1/8"	210"	226"	435	–	–
C-247	2,000-3,500	7 1/2	95 3/8"	141 5/8"	153 5/8"	232 1/2"	248 1/2"	605	AF4, AF8, C9-E, C18-E	C9-W, C18-W
C-3000	3,000-5,500	–	92 1/2"	138 1/8"	150 1/8"	228 13/16"	245 3/32"	621	–	–
C-3010	3,000-4,500	10	113 15/16"	159 9/16"	171 9/16"	250 7/16"	266 1/2"	870	AF8, C18-E	C18-W
C-3015	4,000-5,500	15	119 1/2"	165 1/8"	177 1/8"	256"	272 1/16"	883		
C-3600	4,500-8,000	–	112 1/16"	154 3/4"	161 3/4"	241 3/8"	257 9/16"	995	–	–
C-3620	4,500-7,000	20	151 3/16"	194"	201"	284 7/8"	301 1/4"	1,763	AF12, C18-E	C18-W
C-3625	4,500-7,500	25	152 3/16"	195"	202"	286"	302 1/4"	1,857		
C-3630	5,000-8,000	30	154 3/16"	197"	204"	287 1/2"	303 3/4"	1,934	AF12, C27-E	C27-W
C-4400**	8,000-13,000	–	155"	202 3/16"	211 3/16"	260 7/16"	276 5/8"	1,147	–	–
C-4440**	8,000-11,500	40	175 9/32"	249"	257 13/16"	307"	323 1/4"	1,594	AF18, Two C18-Es	Two C18-Ws
C-4450**	8,000-13,000	50	175 9/32"	249"	257 13/16"	307"	323 1/4"	1,745	AF24, Two C27-Es	Two C27-Ws

*Heights include motor/blower where applicable.

**C-44 Series unit heights include throw-out bins.

***Weight does not include drum or hopper options.

CHOOSING AN AFTER-FILTER

Depending on your application, building specifications and other factors, it may be necessary to use an after-filter in conjunction with the C Series Cyclone. In this case, the Cyclone dust collector captures the heavier contaminants while the after-filter removes the fine particles that may not be seen, but are harmful to breathe. After-filters can be used indoors and outdoors, and can be directly mounted to the C Series Cyclone or remotely located using ducting.

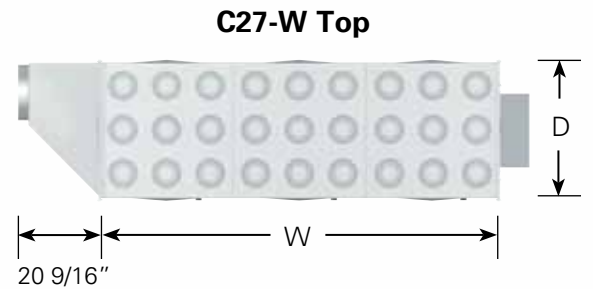
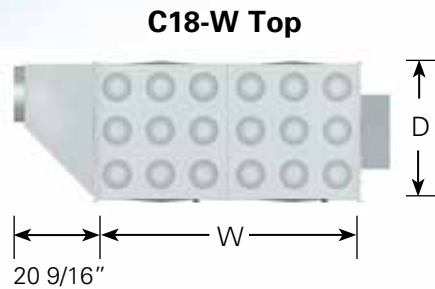
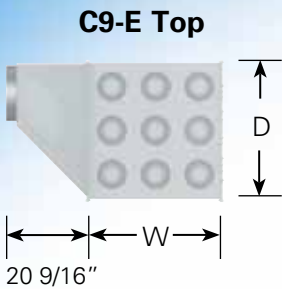
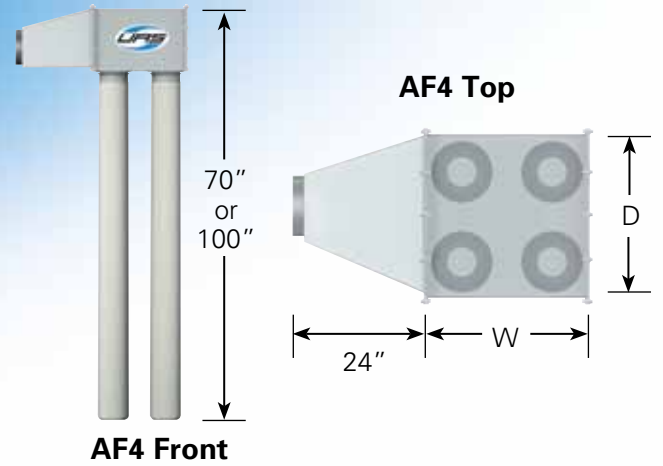

AF- VERSUS C-SERIES

For indoor Cyclone installations, UAS offers AF-Series after-filters. These after-filters bolt directly to the Cyclone blower outlet or are remotely mounted using interconnecting ducting. AF-Series after-filters consist of up to 24 10 oz. polyester felt zippered filter tubes.

Another option is the C-Series after-filter, which can be installed inside or outside your facility. These units

remotely connect to the Cyclone with ducting and empty into 55-gallon drums. Standard filter media are 9 oz. polyester felt bags. Outdoor C-Series units are designated with a "W" for weather enclosure, and are constructed using epoxy-coated cold rolled steel for the harshest environmental conditions. A UAS Representative can help you determine which after-filter is the best fit for your specific application.

AF-SERIES AFTER-FILTERS

Model	W	D	Height Interior	Filter Area (ft ²)	No. of Filters	Unit Weight (lbs)	Recommended Cyclone
AF192	30"	8"	72"	25	1	20	C-192
AF4	51"	27"	89"	72-104	4	91-95	C-203, C-205, C-247
AF8	78"	27"	119"	208	8	182	C-247, C-3010, C-3015
AF12	78"	40"	119"	312	12	244	C-3620, C-3625, C-3630
AF18	105"	40"	119"	468	18	366	C-4440
AF24	132"	40"	119"	624	24	488	C-4450

C-SERIES AFTER-FILTERS

Model	W	D	Height Interior	Filter Area (ft ²)	No. of Filters	Unit Weight (lbs)	Recommended Cyclone
C9-E/C9-W	34"	34"	156"	119	9	600/645	C-203, C-205, C-247
C18-E/C18-W	68"	34"	156"	238	18	1,175/1,225	C-247, C-3010, C-3015 C-3620, C-4440
C27-E/C27-W	102"	34"	156"	357	27	1,750/1,805	C-3625, C-3630, C-4450

E indicates indoor applications only.

W indicates weather enclosure suitable for outdoor installation.

STORAGE HOPPERS

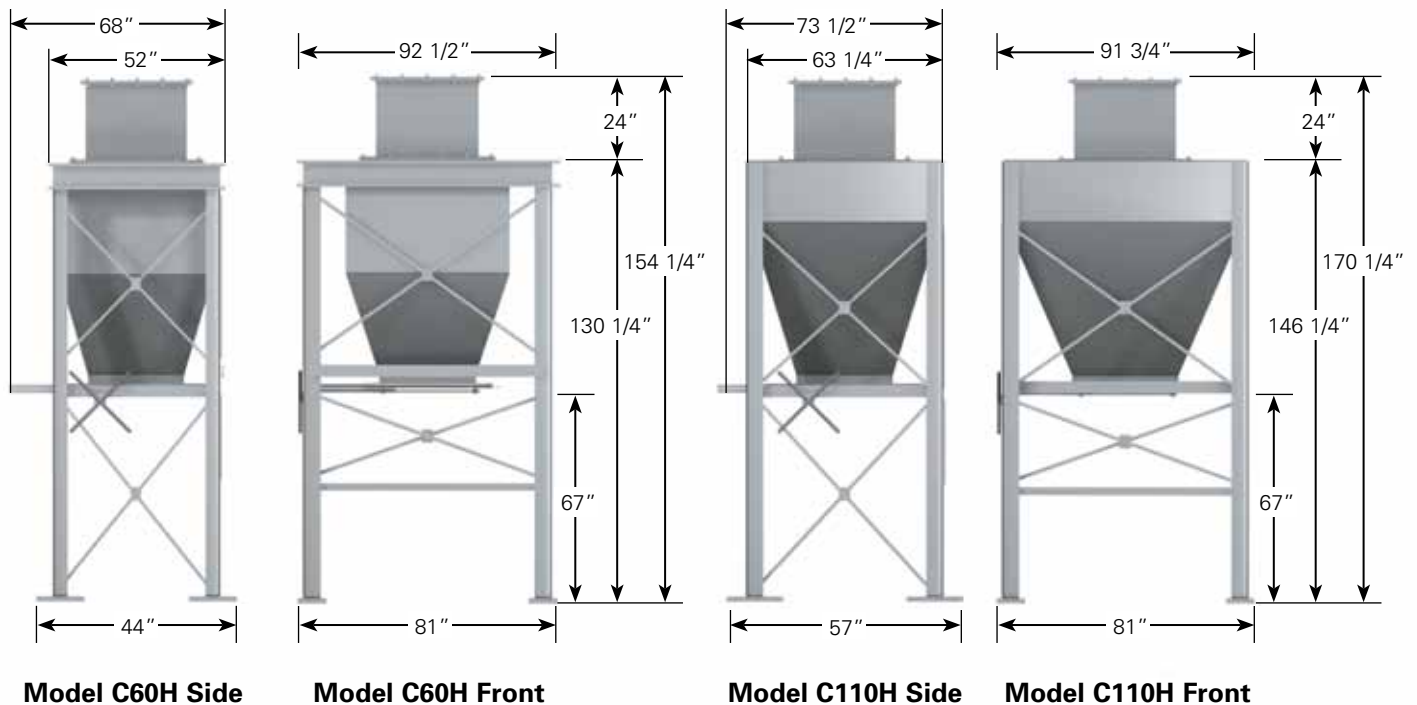

FEATURES AND BENEFITS

Powder-Coated Finish

Components have electrostatically applied paint that helps prevent fading and chalking.

TEFC Motor

Able to withstand indoor and outdoor temperatures.

DIRTY AIR

CLEAN AIR

Compartmentalized Construction

Allows for easy removal of cone section without replacing entire unit.

Blower Housing

Taperlock bushing allows for easy replacement of fan wheel and motor.

Internal Helix

Forces contaminants out of the air and down into the cone section.

True Storage Capacity Discharge Drum

Cone sits flush with discharge area to maximize storage capacity.

Cone Section

Insert Section

Supports steep taper of cone to maximize efficiency.

Complete Unitized Assembly

Unit ships assembled for immediate use.



Clean air. It's what we do.®

CUSTOMIZED SYSTEM

The C Series Cyclone offers a variety of configurations to help meet your company's industrial air cleaning needs. With the assistance of a UAS Representative, you can actually "design" a Cyclone unit and after-filter to match your specific application. Select the direction of the inlet and discharge areas, exhaust clean air back into your plant or outdoors, or choose to use the Cyclone alone or with a UAS after-filter.

Different industrial applications generate varying amounts of dust and debris, so UAS offers a variety of discharge options. For small quantities, you have the choice of 30- and 55-gallon drums that can be configured under the Cyclone unit as a single-or two-drum configuration. For larger loads, you may opt to use the Model C60H hopper, which has a storage capacity of 60 ft³ or Model C110H, which can hold 110 ft³. Additionally, you can add rotary airlocks to your system to constantly discharge dust from a throw-out bin into an external dust storage container.



ENERGY EFFICIENT

C Series Cyclone fans are self-cleaning, material handling radial blades designed to deliver peak airflow with low horsepower to conserve energy. All models can be installed indoors or outdoors, and clean air can be returned inside your factory if the Cyclone is equipped with a UAS after-filter.

DISCHARGE OPTIONS



One 30- or 55-Gallon Drum
(30 gal. shown)



Two 30- or 55-Gallon Drum
(55 gal. shown)



60 ft³ or 110 ft³ Hopper
(C110H shown)

WHY CHOOSE UNITED AIR SPECIALISTS?

A world-renowned reputation. For 45 years, we've been an industry leader in air quality technology — a proven track record that speaks for itself.

Commitment to quality products. Measuring our quality against documented expectations, we practice continuous improvement methods to anticipate challenges and implement successful solutions.

Unparalleled customer support. As a customer-driven solutions provider, we earn credibility and establish successful relationships by exceeding expectations for professional service and attitude.

Innovative technical leadership. Always, we keep technology at the forefront — ensuring continuous product advancements through ongoing investments in design and manufacturing.

UAS HEADQUARTERS – USA

4440 Creek Road
Cincinnati, Ohio 45242
Ph: 513-891-0400
1-800-252-4647
E-mail: info@uasinc.com
www.uasinc.com

UAS – GERMANY

Otto-Hahn-Strasse 6
D-65520 Bad Camberg
Ph: +49-6434-94220
E-mail: info@uas-inc.de
www.uas-inc.de

UAS – UNITED KINGDOM

PO Box 17
Folly Lane
Warrington, Cheshire
England WA5 0NP
Ph: +44-1925-644311
E-mail: uas@clarcoruk.com
www.uasuk.com

UAS – ASIA

7336 Minzhu East Street
Economic Development Zone
Weifang, Shandong 261031
China
Ph: +86-053-62606303
E-mail: sales@uasinc-cn.com
www.uasinc-cn.com



a CLARCOR company

Clean air. It's what we do.[®]